

JBC

www.jbctools.com

INSTRUCTION MANUAL



ALEP250

Angled Automatic-Feed Soldering Iron

This manual corresponds to the following reference:

- ALEP250-A

Packing List

The following items are included:



Angled Automatic-Feed Soldering Iron 1 unit

Allen Screwdriver Ø 2.5 mm 1 unit
Ref. 0033474

Not included, sold separately:

- GALE Guide Kit
- C250 Cartridge



Manual 1 unit
Ref. 0037051

Features and Connections



Tool Assembly

Connect the tool to the control unit following these steps:

Loosen the set screw, insert and push the guide nozzle until it stops (1) and tighten the set screw (2) again. Then plug in the tool connector (3).

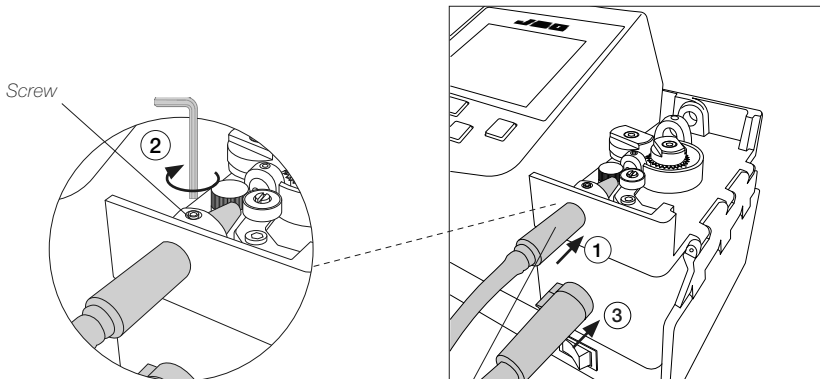

Insert all the way in until it stops

Solder Reel Assembly

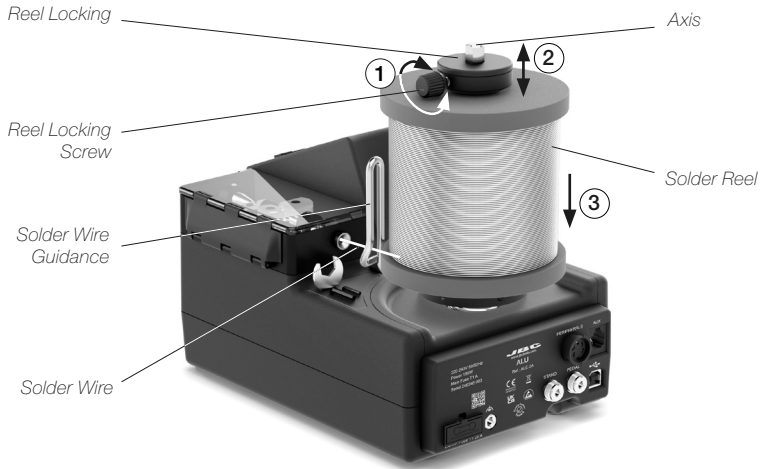

Loosen the reel locking screw (1) and remove the reel locking (2) from the axis.

Assemble the solder reel onto the axis (3).

⚠ Insert the solder reel in such a way —when viewed from above— that the solder wire unwinds on the dispensing mechanism side (4).

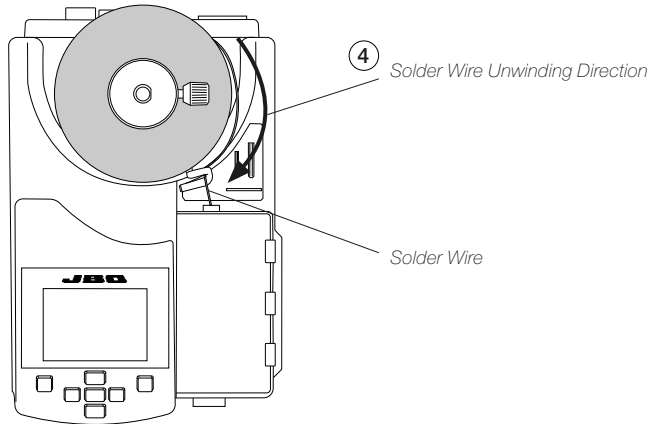

To assemble the reel locking, its conical side must be pointing downwards.
Align the flat side of the axis (5) with the inner flat side (the one with the screw) of the reel locking and reassemble it to the axis (6).

Note: To prevent the solder reel from spinning freely or binding, before tightening the reel locking screw gently press the reel locking down, but only enough to have the solder reel secured in place.

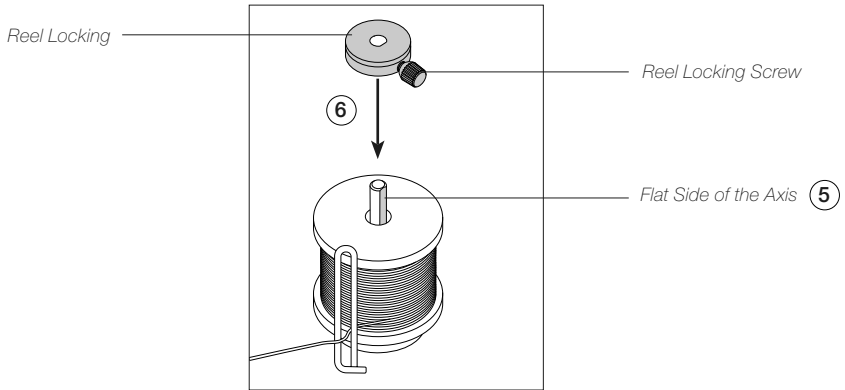

Main Menu Screen

Access to Main Menu by pressing  , select "Feeder settings" (1) and then "Wire diameter" (2) to adjust the value to the current solder wire diameter.

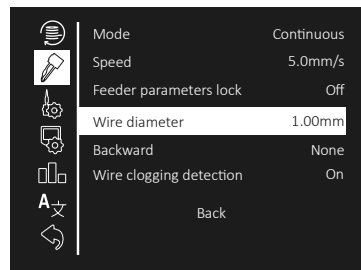
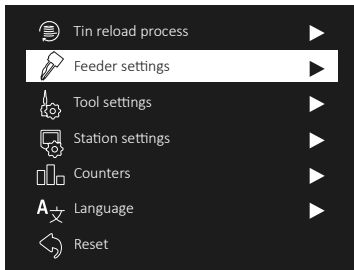

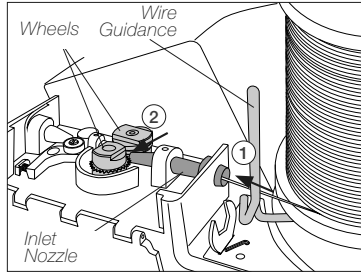

Solder Wire Loading

Pass the solder wire through the wire guidance and introduce the solder wire into the inlet nozzle (1) until it reaches the wheels (2).

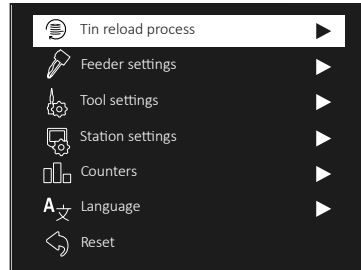

Select "Tin reload process" and then use  to feed the solder wire and advance until it comes out of the outlet nozzle.



If needed, carefully push the wire until it gets locked in between the rotating wheels for the wire to start moving forward. Keep  pressed and after a while, the wire will advance faster.

Make sure the wire passes through the intermediate nozzle (3) and enters the guide tube (4).

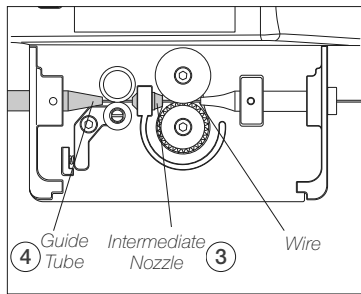

Solder Wire Feeding

Forward the solder wire by pressing the dragging trigger (1) until the wire comes out of the tip.

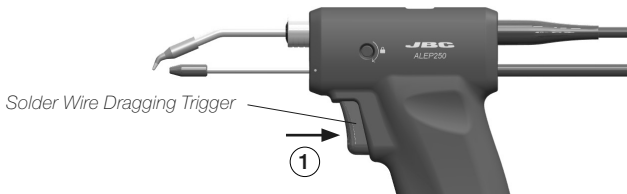

Alternatively, solder wire can also be fed using the pedal P405. The pedal should be plugged in at the rear of the feeder control unit into the pedal connector.



Solder Wire Unloading

With Solder Wire Perforation

To unload solder wire with perforation that has already passed through the guide tube, cut the wire between the wire guidance and the inlet nozzle (1).

To extract the wire out of the tube, hold the tool on your hand and press  until the wire stops moving forward.

Grasp the wire coming out of the outlet nozzle with a pliers and pull from it until it is completely out.

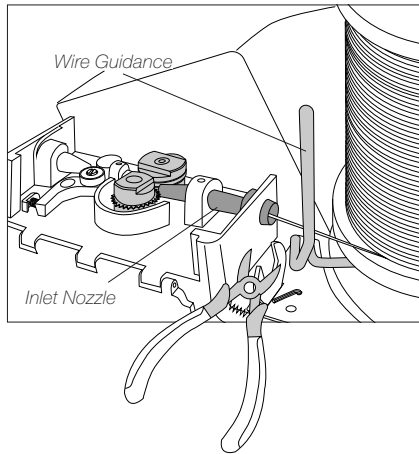

Without Solder Wire Perforation

When using a kit without solder wire perforation, press  until the wire is completely wound to unload the solder wire. It is best to rotate the reel by hand as the wire is being pulled back in order to keep it neatly arranged on the reel.

Or, if preferred, proceed as described before for perforated solder wire unloading.

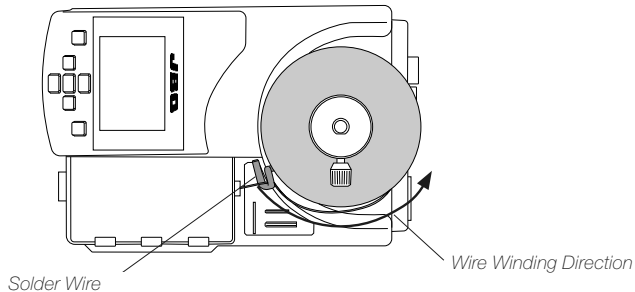

Compatible Cartridges

This tool works with C250 and C250E cartridges. Find the model that best suits your soldering needs at www.jbctools.com.



Conical Bent



Bevel



Chisel Bent

Cartridge Exchange

For a safe cartridge exchange, unplug the tool or turn the station off before following these guidelines:

1. Loosening and Removing

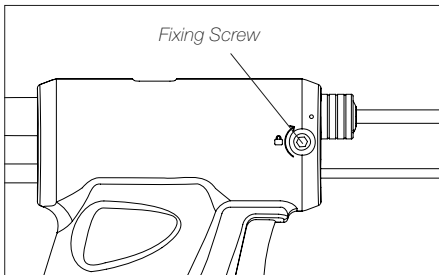

Loosen the cartridge fixing screw with the supplied Allen screwdriver and remove the cartridge. Use JBC's PLR195 cartridge extractor pliers to remove it if still hot.

2. Inserting

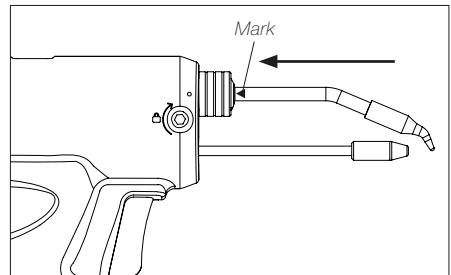

Important: Insert the cartridge up to the mark for a correct connection.

3. Aligning

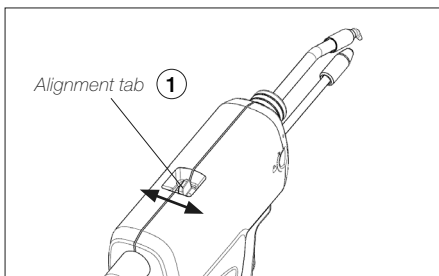

Use the pliers to align the cartridge with the outlet nozzle. Use the alignment tab of the tool (1) to make a fine adjustment. Make sure the tab is set in the middle when inserting the cartridge to allow room for movement to both sides.

4. Fixing

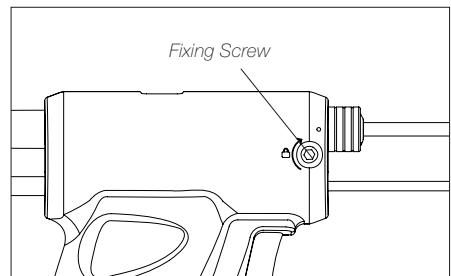

Important: Tighten the screw again. This is necessary for the tool to function properly.

Cartridge Alignment Example

The cartridge should always be aligned with the exit of the outlet nozzle. The image on the left shows a slightly deviated cartridge, while the image on the right shows a properly aligned cartridge. Use the alignment tab of the tool before fixing the cartridge to make sure the cartridge is well positioned.

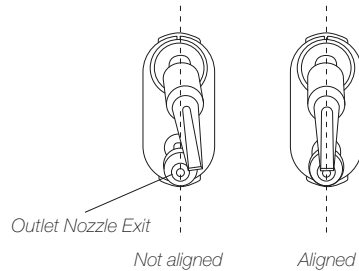

Replacing Sealing Plugs

The sealing plug prevents undesirable flux vapors or particles from entering the tool, and its usage is highly recommended. If the sealing plug is not used, particle inflow can lead to faulty performance due to poor cartridge contact or even to the tool being rendered unusable.

Note: Check the condition of the plug periodically and replace it as soon as wear or a crack appears in the sealing area of the cartridge.

⚠ Before replacing the sealing plug, unplug the power supply and make sure the device is not hot.

Tool	Sealing Plug
ALE250, SF250, ALEP250	OB2000 **

** Each ref. contains 10 units.

1. Removing Sealing Plug

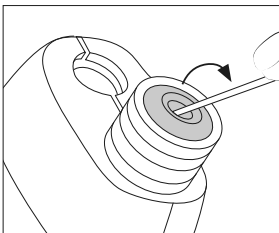

Introduce a small shaft or screwdriver, not deeper than 8 mm, and lift and pull out the sealing plug. Never use a cartridge to do this operation.

2. Mounting Position

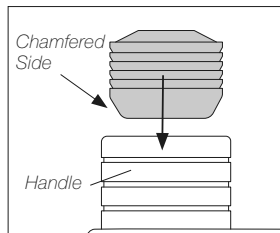

Note: The chamfered side has to be positioned towards the tool.

3. Inserting Sealing Plug

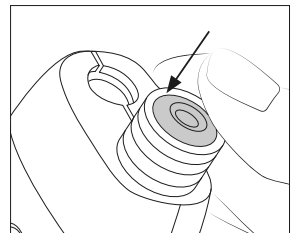

Push the sealing plug all the way into the tool.

Guide Tube Set Replacement

First, make sure that the tool has cooled down and unload any remaining solder wire that might still be inside the guide tube. Unplug the tool from the control unit.

Loosen the guide tube set screw (1), take out the guide set (2) and insert the desired one.

Leave a gap of 5 to 7 mm (0.19 to 0.27 in) between the cartridge tip and the outlet nozzle (3).

Once the guide nozzle length is adjusted, tighten the guide set screw (1).

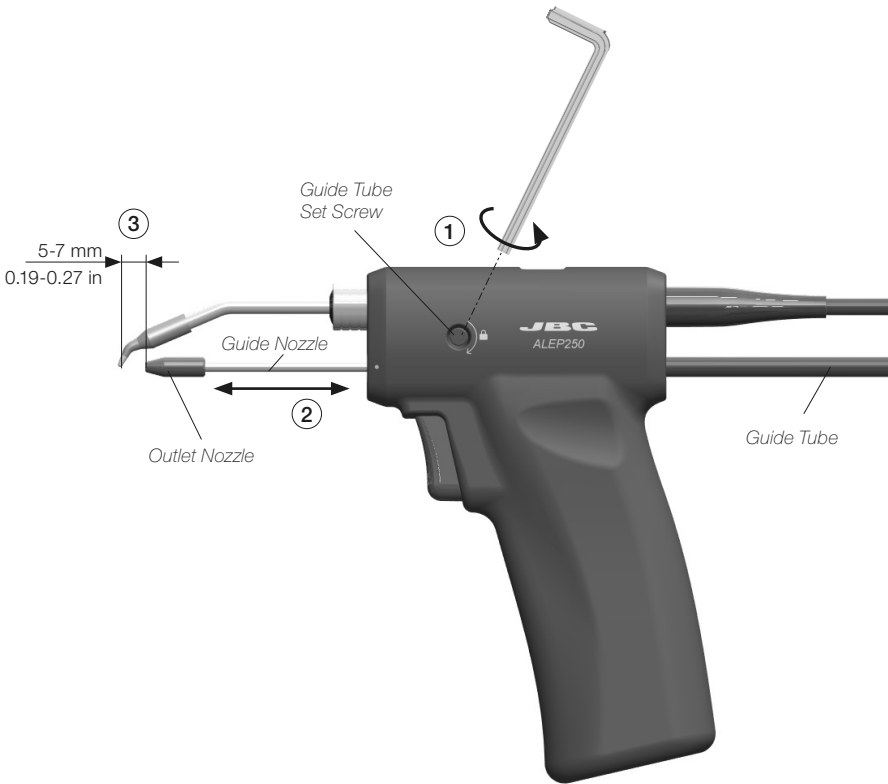

Outlet Nozzle Replacement

Flux can cause clogging at the outlet nozzle of the guide tube set and it can be necessary to replace the worn or clogged outlet nozzle.

Note: There is a nozzle size for each soldering wire diameter. The use of the nozzle is necessary as its inner diameter is adjusted to the solder wire diameter and guides the wire with greater precision.

To replace the outlet nozzle, follow these steps:

First, make sure that the tool has cooled down and unload any remaining solder wire that might still be inside the guide tube. Unplug the tool. Loosen the guide tube set screw (1) and detach the guide tube set from the tool for easier handling.

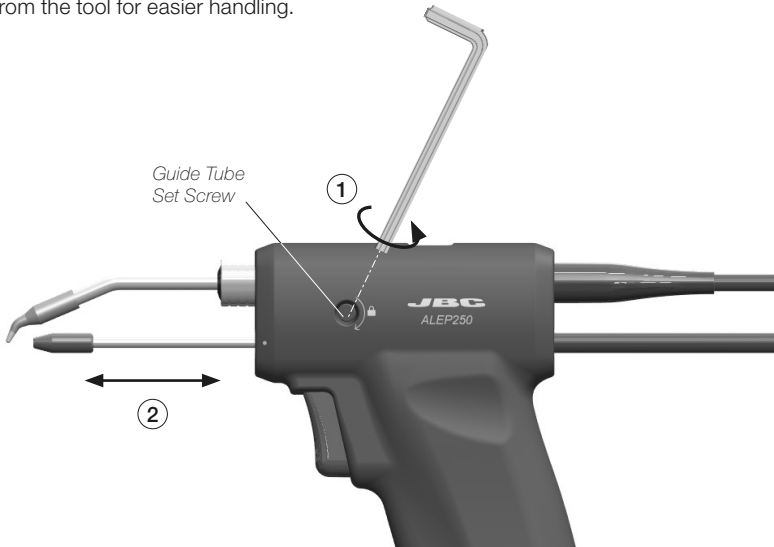

Unscrew the outlet nozzle. If the outlet nozzle is stuck onto the guide nozzle due to flux clogging, soak it in alcohol to release it.

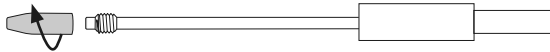

Replace the outlet nozzle and screw it back onto the guide nozzle.

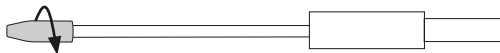

Assemble the guide set onto the tool following the disassembly steps in reverse order.

GALE Guide Kits

GALEXV-B WITH SOLDER WIRE PERFORATION

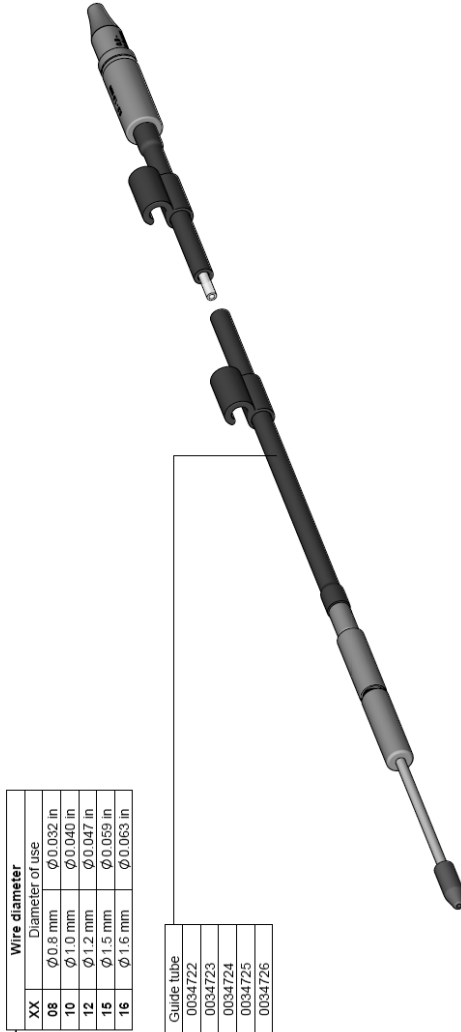

XX	Wire diameter
	Diameter of use
08	Ø 0.8 mm
10	Ø 1.0 mm
12	Ø 1.2 mm
15	Ø 1.5 mm
16	Ø 1.6 mm

Guide tube
GALE08V-B 0034722
GALE10V-B 0034723
GALE12V-B 0034724
GALE15V-B 0034725
GALE16V-B 0034726

SPARE PARTS

Wire Ø	Outlet nozzle	Nozzle	Guide wheel	Blade	Blade clamp	Inlet nozzle	Interm. nozzle	Counter wheel	Screws	Threaded stud
GALE08V-B	0033986	0032612	0021696	0021555	0018638	0018632	0024955	0026693	0026635 (x2)	0026636 (x3)
GALE10V-B	0033987		0019170			0024956				
GALE12V-B	0033988		0019171			0024957				
GALE15V-B	0033989		0024233			0024958				
GALE16V-B	0033991		0024959			0024959				

GALE Guide Kits

GALEXD-B WITHOUT SOLDER WIRE PERFORMANCE

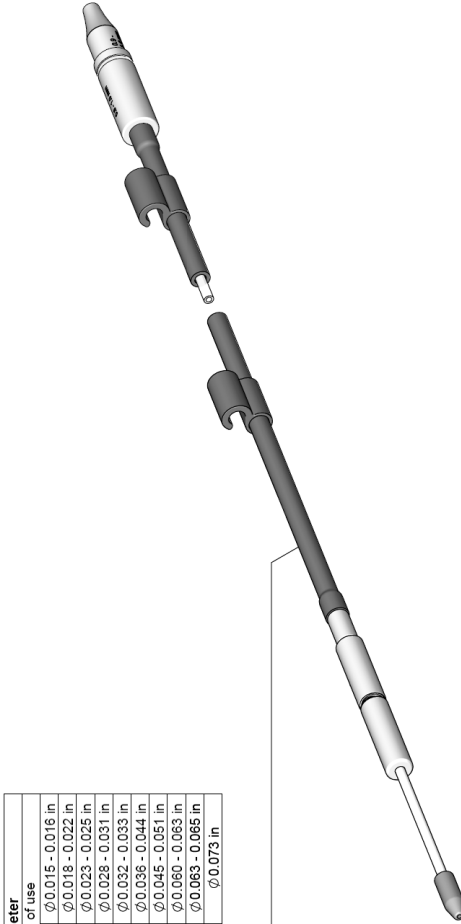

XX	Wire diameter	Range of use
04	∅0.38 - 0.40 mm	∅0.015 - 0.016 in
05	∅0.46 - 0.56 mm	∅0.018 - 0.022 in
06	∅0.60 - 0.64 mm	∅0.023 - 0.025 in
07	∅0.70 - 0.78 mm	∅0.028 - 0.031 in
08	∅0.80 - 0.82 mm	∅0.032 - 0.033 in
10	∅0.90 - 1.10 mm	∅0.036 - 0.044 in
12	∅1.14 - 1.27 mm	∅0.045 - 0.051 in
15	∅1.50 - 1.57 mm	∅0.060 - 0.063 in
16	∅1.60 - 1.63 mm	∅0.063 - 0.065 in
18	∅1.80 mm	∅0.073 in

Guide tube	
GALE04D-B	0034718
GALE05D-B	0034719
GALE06D-B	0034720
GALE07D-B	0034721
GALE08D-B	0034722
GALE10D-B	0034723
GALE12D-B	0034724
GALE15D-B	0034725
GALE16D-B	0034726
GALE18D-B	0034727

SPARE PARTS

Wire ∅	Outlet nozzle	Nozzle	Traction wheel	Support wheel	Inlet nozzle	Intern. nozzle	Counter wheel	Screws	Threaded stud
GALE04D-B	0033982			0020345		0024954			
GALE05D-B	0033983			0019519	0019520	0025293			
GALE06D-B	0033984				0018632	0024955	0026693	0026695 (X2)	0026696 (X3)
GALE07D-B	0033985			0019480	0019170	0024956			
GALE08D-B	0033986	0032612	0019479			0024957			
GALE10D-B	0033987			0019481	0019171	0024958			
GALE12D-B	0033988				0024233	0024959			
GALE15D-B	0033989			0028367	0024234		0026694		
GALE16D-B	0033991								
GALE18D-B	0033992								

Maintenance

- Before carrying out maintenance, always unplug the stand and the tool.
- Check periodically that the metal parts of the tool and the stand are clean to ensure detection of the tool when it is in the stand. Use a damp cloth or alcohol.
- Periodically check all cables and tubes connections.
- Replace any defective or damaged pieces. Use original JBC spare parts only. Repairs should only be performed by a JBC authorized technical service.

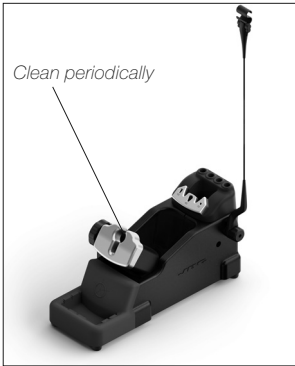

Safety



It is imperative to follow safety guidelines to prevent electric shock, injury, fire or explosion.

- Do not use the tool for any purpose other than soldering or rework.
- The power cord must be plugged into approved bases. Be sure that it is properly grounded before use. When unplugging it, hold the plug, not the wire.
- The tool should be placed in the stand when not in use in order to activate the sleep mode. The soldering tip, the metal part of the tool and the stand may still be hot even when the station is turned off. Handle with care, including when adjusting the stand position.
- Avoid the contact of flux with skin or eyes to prevent irritation.
- Be careful with the fumes produced when soldering.
- Keep your workplace clean and tidy. Wear appropriate protection glasses and gloves when working to avoid personal harm.
- Utmost care must be taken with liquid tin waste which can cause burns.
- This appliance can be used by children over the age of eight and also persons with reduced physical, sensory or mental capabilities or lack of experience provided that they have been given adequate supervision or instruction concerning use of the appliance and understand the hazards involved. Children must not play with the appliance.
- Maintenance must not be carried out by children unless supervised.

Specifications

ALEP250

Angled Automatic-Feed Soldering Iron

Ref.: ALEP250-A

- | | |
|---|--|
| - Total Net Weight: | 120 g / 0.26 lb |
| - Package Dimensions/Weight:
(L x W x H) | 245 x 185 x 45 mm / 230 g
9.65 x 7.28 x 1.77 in / 0.51 lb |

Complies with CE standards.
ESD safe.

JBC

Warranty

JBC's 2 year warranty covers this equipment against all manufacturing defects, including the replacement of defective parts and labor.

Warranty does not cover product wear or misuse.

In order for the warranty to be valid, equipment must be returned, postage paid, to the dealer where it was purchased.



This product should not be thrown in the garbage.

In accordance with the European directive 2012/19/EU, electronic equipment at the end of its life must be collected and returned to an authorized recycling facility.



www.jbctools.com